

CHAPTER 6

A TYPICAL GUN AND MISSILE WEAPONS SYSTEM

This chapter will give you a brief overview of a typical gun and missile weapons system. The system described here is made up of elements that have been taken from Terrier and Tartar system. It illustrates the typical composition and functioning of gun and/or missile weapons systems (not including all weapons, such as depth charges, bombs, etc.). And it will provide the background that will lead to a better understanding of the system you have aboard ship.

WEAPONS SYSTEM CONCEPT

You have already studied the fundamental fire control problem. Now you will study some of the equipment used to solve that problem.

The effective use of any weapon requires that a destructive device (containing an explosive) be delivered to a target—usually a moving target. To deliver the weapon accurately, we must know both the location and the velocity of the target. Most targets now travel faster than sound, and must therefore be engaged at great distances. Against such targets, a weapon is most effective when it is used as part of a weapons system. A weapons system is the combination of a weapon (or multiple weapons) and the equipment used to bring their destructive power against an enemy.

A weapons system includes:

1. Units that detect, locate, and identify the target.
2. Units that direct or aim a delivery unit.
3. Units that deliver or initiate delivery of the weapon to the target.
4. Units that will destroy the target when in contact with it or near it. These units are usually termed weapons. Figure 6-1 illustrates these units and groups of units that make up a weapons system.

DETECTING UNITS

The first steps in using a weapons system and solving the fire control problem are to detect, locate, and identify the target. Initial contact with a surface or airborne target may be visual, or it may be made by radar. It is difficult to detect a target visually at long range, or even at short range when visibility is poor. For that reason, targets are usually detected by search radar. Search radars, as you know, keep a large volume of space around your ship under continuous watch. They give the ship fairly accurate information about the target's position, even when the target is hidden by fog or darkness. To determine a target's position we must know its range, its direction from the ship, and, for an airborne target, its elevation. Radar gives all three of these coordinates. (Radar has certain disadvantages, too. For example, it can be detected by an enemy at about four times the range at which it can pick up an enemy target.)

Optical devices are used as a supplementary source of information on slow-moving targets at relatively short range. They are useless against missiles or jet aircraft, which must be engaged while they are still beyond the range of optical instruments.

After we have detected and located a target, we must identify it. How can we identify a target that may be several hundred miles from our ship? The answer lies in a device called IFF (Identification, Friend or Foe). See Figure 6-1. Radar alone cannot tell the difference between friendly or enemy targets. But the IFF equipment can challenge an unidentified target, and determine from the answer whether the target is friendly. The equipment consists of two major units - the challenging unit which asks the question, "friend or foe," and the transponder which answers the question. IFF equipment is used in conjunction with search radar, and sometimes fire control radar. Briefly, this is how it works. To challenge a target you press a switch attached

CHAPTER 6 - A TYPICAL GUN AND MISSILE WEAPONS SYSTEM

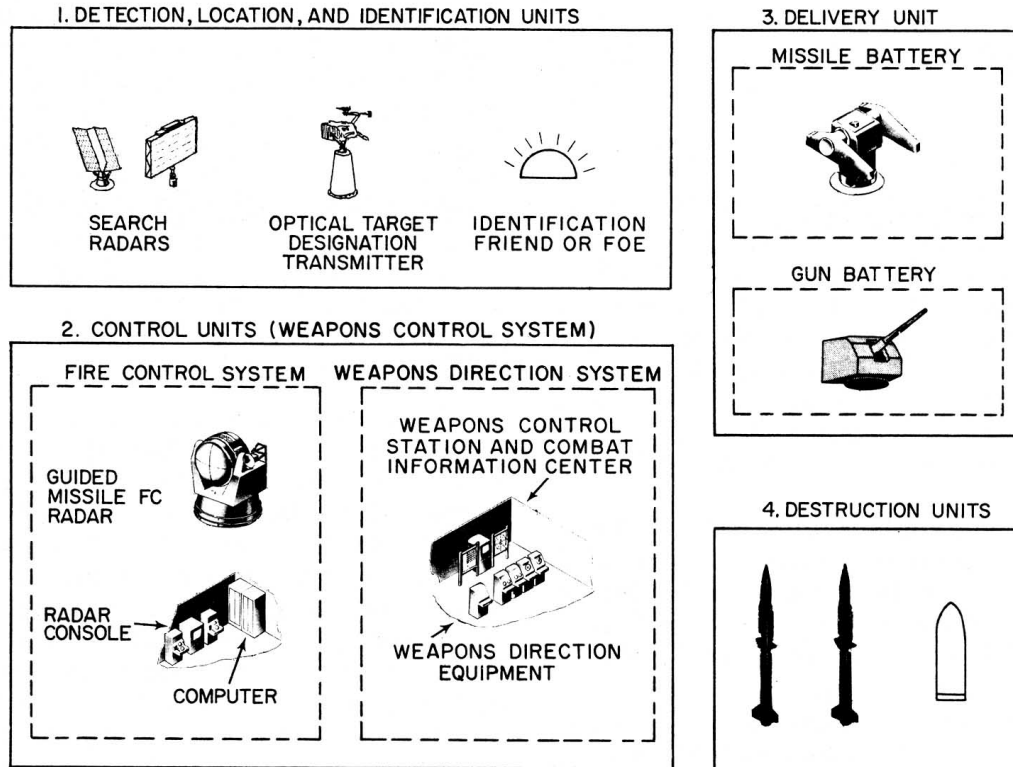

12.41

Figure 6-1.— Basic composition of a gun and missile weapons system.

to the radar. The transmitter will then send out a pulse of low power radio energy toward the target. If the target is friendly it will carry a transponder, which consists of a receiver and a transmitter. When the receiver picks up a challenge, it causes the transmitter to send out an answering pulse or pulses. The answer is usually a coded message. It is picked up by the challenging unit's receiver and sent to the indicator of the search radar. An enemy target will not know the code and therefore will not be able to answer the challenge.

CONTROL UNITS

Control units in a weapons system develop, compute, relay, and introduce data into a delivery unit, a weapon, or both. They direct, control, or guide the weapon (destructive device) to the target, and cause it to function in the desired way. These units form the heart of the weapons system. Note (fig. 6-1) that there are two groups of units in the control unit: Fire control system, and weapons direction system. These will be discussed in more detail later.

Types of Control Units

The devices that perform the control functions include:

DATA TRANSMISSION SYSTEMS that send target position information developed by the detecting units to the rest of the weapons system, and convey other data among the components of the weapons system. Examples are synchro, resolver, and potentiometer circuits.

COMPUTER DEVICES to process the input data from the detecting units and other sources, and put out the aiming and program instructions that cause the weapon to reach its target. Examples are rangekeepers and computers.

DISPLAY UNITS that display information at various locations on the ship. These are generally electronic or optical devices.

DIRECTING DEVICES which, with the aid of detecting devices, establish target location to a finer degree than the detecting devices alone. Directing devices can also function to directly or indirectly control missile flight. Examples are gun and missile directors, and radar sets.

REFERENCE DEVICES such as stable elements, which establish reference planes and lines to stabilize lines of fire, lines of sight, and other references. These units are gyroscopically controlled.

DELIVERY UNITS

Broadly speaking, delivery units launch or project destructive units toward the target. Examples are guns, missile and rocket launchers, torpedo tubes, and depth charge projectors. Don't think of these devices as weapons. The term WEAPON is properly applied to the destructive unit that is launched or projected. Thus a guided missile launcher is not, strictly speaking, a weapon; the missile itself is the weapon.

To be employed effectively against their targets, all weapons must either be aimed at their targets or must be programmed during flight. They may require both aiming and programming. Programming is the process of setting automatic equipment to perform operations in a predetermined step-by-step manner. Aiming and programming are done at or before the time of launching, either by or through the delivery device. This function is characteristic of all delivery devices, even the simplest. Aiming the destructive device (weapon) at the target may be done simply by positioning the delivery device (a gun barrel or launcher guide arm, for example). Or it may be done without aiming the delivery device, by placing program instructions in the weapon. Some missiles are programmed to start searching for the target after the launching phase is over. Examples of other programmed functions that could be performed in the weapon are ignition of propulsion units and arming of the warhead after a designated number of seconds of flight.

Types of Delivery Devices

Guns direct (aim) the projectiles by positioning the gun barrels, and the propulsion energy is provided by the propellant charge, which may be a separate component as in bag guns and semi-fixed ammunition, or enclosed in the powder case which is crimped to the projectile.

MISSILE LAUNCHERS retain and position missiles during the initial part of the launching phase, and, by means of attachments to the launcher, feed steering, vertical reference, and program information into the missile up to the instant of launch. Of course there are other types of delivery devices, such as torpedo tubes,

depth charge and thrown weapon projectors, and rocket launchers. But guns, and missile and rocket launchers are most important to you as a GMM. You will be required to understand their function in the weapons system. The GMGs are responsible for operation of depth charge and thrown weapon projectors, rocket launchers, and the Basic Point Defense Surface Missile System. When you are ready for E-8 you will need to know about those also, so do not evade learning about them as you go along. Use your opportunities for learning.

DESTRUCTIVE UNITS

The end purpose of detection units, delivery units, and control units is to cause the destruction unit to intercept or pass near the target. It is then the function of the destruction unit to destroy or inflict maximum damage on the target. Except for projectiles used in small arms, and some of those used in calibers up to 40-mm, weapons and projectiles used in combat are loaded with explosives, and equipped with devices to set off their explosion at the proper time. For some weapons and projectiles, the proper time is the instant the weapon makes physical contact with the target. For those designed to penetrate targets protected by armor or concrete, the proper time is after penetration. Still others are intended to explode when they reach the vicinity of the target.

In some special types, the explosive is intended only to rupture the container so the contents can be disseminated in the area selected. Examples of these are various types of gas bombs (lethal or merely disabling), biological warheads, and various chemical warheads. In these types, the explosive is not the destructive force.

BASIC WEAPON COMPONENTS

All weapons and projectiles have these components.

1. A CONTAINER or BODY which houses the internal components. The body may have such other functions as piercing armor, breaking up into high velocity fragments when the weapon or projectile explodes, or improving the weapon's ballistic characteristics by means of fins or streamlining.

2. A DETONATING DEVICE (called a fuze, exploder, detonator, etc.) which initiates explosion at the proper time, and includes safety devices to prevent premature explosion.

CHAPTER 6 - A TYPICAL GUN AND MISSILE WEAPONS SYSTEM

3. A PAYLOAD which is the "reason for being" of the weapon or projectile. The payload usually consists of high explosive or nuclear material. Exceptions were mentioned above as special types.

Weapons of some types have their own propulsion systems. The outstanding examples are guided missiles, torpedoes, and rockets. With the exception of rockets, weapons that have a propulsion system also contain guidance and control systems.

To summarize the weapons system concept, we can say that any weapons system contains four major functional components, which are interrelated to make up the system as a whole (fig. 6-1).

REPRESENTATIVE SHIPBOARD WEAPONS SYSTEM

The equipments making up each of the four categories of functional components are enclosed in separate blocks (fig. 6-1). We will introduce and discuss the four groups of equipments in the order in which they operate to solve the fire control problem.

TARGET DETECTION, LOCATION, AND IDENTIFICATION UNITS

The first contact with an airborne target is usually made by air search radar. These radars are designed to keep a large aerial volume under nearly continuous observation. Jet aircraft travel at high speed, and may launch guided missiles against our ships from a great distance. This requires that our radar search be carried out to long range. To cover the necessary area, search radar uses a wide beam. In addition, most search radar antennas rotate as they search. Targets detected during this scanning process show up on the radar's target display indicators as alternately fading and brightening spots. It is difficult to determine target range, course, and speed from these spots. All of these factors limit the accuracy with which search radar can provide information about target position. For target information of the required accuracy, we must depend on fire control radars. We will discuss these radars later in this chapter.

After the search radar has detected a target and determined its approximate location, the next step in the development of the fire control problem

is to identify the target. The problem of recognizing and identifying a friend or foe is as old as warfare. Passwords, flag hoist signals, and even the uniforms we wear are identification devices that have been developed through the years.

In modern warfare the identification problem is urgent. Radar systems present targets in the form of spots or spikes (called echoes) on a radar screen; but friendly and enemy targets look alike on the screen. Furthermore, high speed planes and guided missiles give us very little time to solve this problem. And when friendly fighter aircraft pursue enemy planes to within gun range of our ships, the identification problem is acute.

The safety of ships in a task force is another phase of this problem. If the enemy were able to use our identification system, he could make deadly approaches before his presence were known. In the past, enemy planes have actually followed our fighters to their mother ship and discovered the location of the carrier and her escorts. In such an instance the destruction of the enemy planes is vital, so that the location of the fleet will not be revealed.

Before we leave the subject of the major equipments that fall in the category of detection, location, and identification units, we want to emphasize that solution of the fundamental fire control problem begins with detection of a target. The next step is to locate it. And the final step in this initial phase is to identify it as friend or foe. These three steps combine to form the first phase in the functioning of a weapon system. At this point you should begin to see that you must think in terms of a complete weapons system in order to understand the functioning of each individual component in the system.

In the discussion above we have considered only air targets. Surface targets and underwater targets must also be detected and identified, and their location determined. A search radar is used to scan the area for surface targets; sonar is used for the detection of underwater targets.

Now let's consider the CONTROL UNITS in group (2) (fig. 6-1). These are not the control panels we described in chapter 5, which control only the missile launching system.

CONTROL UNITS IN A WEAPONS SYSTEM (THE WEAPONS CONTROL SYSTEM)

Once the air search radar detects and roughly locates the target, and the IFF equipment has determined whether it is a friend or foe, the target information from these sources is sent to the equipments that we have called control units. These units include fire control radars, computers, weapon direction equipment, stable elements, and many other mechanical, electrical, and electronic instruments.

Traditionally, the systems of equipment used for the control of a particular battery of guns, torpedoes, or other conventional weapons, have been known as fire control systems. But the complexity of guided missiles has required the introduction of new fire control instruments, and new terms to describe them. In the following paragraphs we will define some of these terms.

All of the units that are enclosed by the solid line in block (2) of figure 6-1 form a WEAPONS CONTROL SYSTEM. A weapons control system is defined as a group of interconnected and interrelated instruments that are used to control the delivery of effective fire on selected targets. The system is composed of a WEAPONS DIRECTION SYSTEM and one or more Fire Control Systems. It includes all the equipment necessary to control target assignment for guns, missiles, and ASW weapons.

Weapons Direction System

Any WEAPONS SYSTEM begins to function as a system as soon as a target is detected. A FIRE CONTROL SYSTEM however, begins its functioning by determining target position with all possible precision, so that a line of fire can be established. Before a fire control system can establish a line of fire, certain preliminary processes must take place within the weapons system. These processes are:

1. Detection of a target by search radar or other devices.
2. Identification of the target by IFF or other devices.
3. Evaluation of the target.
4. Designation of the target to a fire control system.
5. Acquisition of the target by a fire control system.

The weapons direction system coordinates and monitors the operations of the missile launching system and the fire control systems.

The target position and identification information obtained during the first two processes is sent to the CIC (Combat Information Center), and to the WCS (Weapons Control Station, Fig. 5-7). These two organizations of equipment and personnel may be in the same compartment or in separate locations (fig. 5-8). Here, we will consider them to be in the same compartment. This compartment also contains the units that make up part of the Weapons Direction System (WDS). This particular group of equipments is known collectively as Weapons Direction Equipment (WDE). The WDE, and minor units that support its function, make up the Weapons Direction System of a ship.

The purpose of the WDS is to perform those functions that are required during three phases of a tactical situation. During the first phase, the equipment provides electronic means for the display of targets detected by search radars, and it provides devices for selecting and initially tracking the targets that show up on the displays. These displays are similar to the PPIs that you are familiar with or have read about in Basic Electronics, NavPers 10087-B. Targets show up as bright pips or dots on the face of the scope.

As the tactical situation develops, and the targets get closer, the system provides means for evaluating the situation and assigning a fire control system or systems to acquire and track designated targets. This is the second phase in the tactical situation. The third and last phase requires that weapons be assigned by the WDS to the fire control system that is tracking the target. Before weapons are assigned, the tactical situation must be reevaluated.

EVALUATION. - So far in this discussion, we have introduced three new terms: evaluation, designation, and acquisition.

In fire control, evaluation is concerned with these questions.

1. What does the target intend to do? Is it going to pass close to the ship for observing, or is it going to launch an attack?

2. How threatening to the ship's safety is the target? If its obvious intent is to attack, how much time does the ship have to launch a counterattack? And what weapons should the ship use to repulse the target?

3. What kind of attack is the target capable of launching? If the target carries missiles, the ship must launch weapons that will reach the target before it can launch its missiles.

CHAPTER 6 - A TYPICAL GUN AND MISSILE WEAPONS SYSTEM

There are other factors involved in evaluating a tactical situation, but these sample questions should give you some idea of what the term "evaluate" means.

The equipment in the weapons direction system I presents a complete visual picture of the tactical situation. It displays all the targets that have been detected by the search radars. Each target must be evaluated with respect to the overall defense picture. The process of target evaluation is performed by ship's personnel with the help of equipment in the WDS. Decisions are made to bring the ship's weapons to bear on the most threatening targets. These selected targets must be assigned to the appropriate fire control systems. The assignment process includes two functions - designation and acquisition.

DESIGNATION. This is the step taken to assign the tracking element (director, radar, radar set) of a fire control system to a particular target. On the basis of target evaluation and the availability of fire control systems (some of which may be disabled, or busy with other targets), decision is made to assign a fire control system to the target. This is usually done by pressing a button to activate circuitry that transmits target position information from the weapons direction system to the antenna positioning circuits of a radar set, or the power drives of a director. These units automatically move the radar antenna to the position designated by the WDS. If the designation data is inaccurate the radar set must search for the target.

The searching process may last for a fraction of a second or longer, depending on the accuracy of the designation information and other factors. Once the fire control radar has found the target and starts to track, it can be said that it has acquired the target.

ACQUISITION. Acquisition by the tracking device is the process of accepting a designation from the WDS equipment which acquired the target, and starting to track it. A target is acquired when the radar has "gated" it, or the crosshairs in the director sights are on it.

In the preceding discussion we indicated that the WDS was further subdivided into the weapons direction equipment, and other equipment related to the overall function of the weapons direction system.

Fire Control Systems

A ship may have several fire control systems, depending on the number and type of weapons aboard. It may also have more than one missile

or gun fire control system, or a combination of both. In addition, the ship may also have an underwater battery fire control system.

Missile fire control systems include directors, radars, and computers. The major functions of these components include tracking of the designated target, transmission of the target data to the weapons direction system, aiming of the launcher, and guidance of the missile to the target.

The GMM does not operate the fire control equipment but he needs to have some knowledge of what is taking place so he can cooperate intelligently with the FTs.

DELIVERY UNITS

Chapter 5 described the delivery units (launchers) for Terrier, Talos, Tartar, and Standard missiles. The launchers for Asroc Launching Group Mk 16 which incorporates the Asroc Launcher Mk 112, is the responsibility of GMTs and is not described in this text. Shipboard gun systems may include 3-inch, 5-inch, and 8-inch guns. These are the concern of the GMGs, but you need to know about them when your chance comes to make E-7 or E-8.

DESTRUCTION UNITS

A typical weapons system has gun projectiles and one type of missile; larger ships have more than one size and type of projectiles and two or more types of missiles. The different missile rounds of the Navy are described in other chapters of this text; other naval ordnance is described in Basic Military Requirements, NavPers 10054-C, with which you should be familiar.

In the following articles we shall describe the units that make up the weapons direction system.

TYPICAL WEAPONS DIRECTION EQUIPMENT

Some of the major tasks performed by the weapons direction equipment (WDE) are director-to-target assignment, launcher-to-director assignment, salvo select, missile warmup, missile firing, and emergency and dud firing. The WDE is the link between the search radars and the fire control system.

It is worth repeating that the weapons direction equipment includes displays and controls for the evaluation of target data, and for the selection and engagement of targets so as to ensure the

most effective use of the gun and missile batteries. A typical WDE consists of one or more Target Selection and Tracking consoles, a Director Assignment console, a Weapon Assignment console, and the necessary cabinets to house power supplies and computer units.

TARGET SELECTION AND TRACKING CONSOLE

Figure 6-2A shows a typical target selection and tracking console. Regardless of the mark or modification, they all have the same general shape. The console is used for selecting and tracking targets detected by search radars. The principal indicator on a console of this type is a PPI (Plan Position Indicator) (fig. 6-2B), that displays the bearing and slant range of all targets picked up by a selected search radar. The primary controls are a pantograph arm for selecting and tracking targets, and pushbuttons for assigning target-to-tracking channels. Other controls are provided for selecting various search radars for the PPI display, for selecting certain range scales, and for inserting target position and rate of movement data into the tracking channels.

Targets are displayed on the scope as radar video (pips). To select a target and assign it to a tracking channel, you position the pantograph sighting ring (fig. 6-2B) over the target pip and then press a channel button. Pressing the button gains electrical access to that channel, and simultaneously causes an identifying channel letter to appear next to the target pip. Successive corrections of pantograph position develop target course and speed data that are inserted into the tracking channels.

DIRECTOR ASSIGNMENT CONSOLE

The primary purpose of this console is to provide the information display and controls required to assign fire control systems to the targets being tracked by the target selection and tracking console operator, when it is determined that a specific target or targets should be engaged. Figure 6-3 shows the panel layout of the director assignment console for our basic WDE. Two plots are provided on the face of the console - a plan plot on the left, and a multipurpose plot on the right.

The plan plot (fig. 6-3A) Shows three range rings, and indicates true bearing with north at the top. Each target being tracked by that target selection and tracking console operator appears on

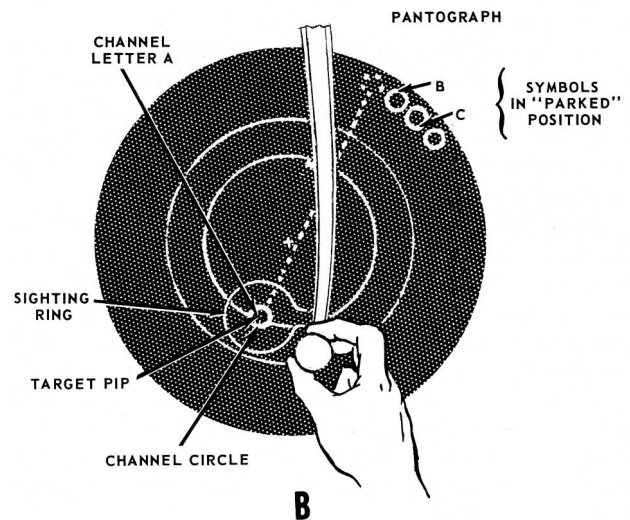
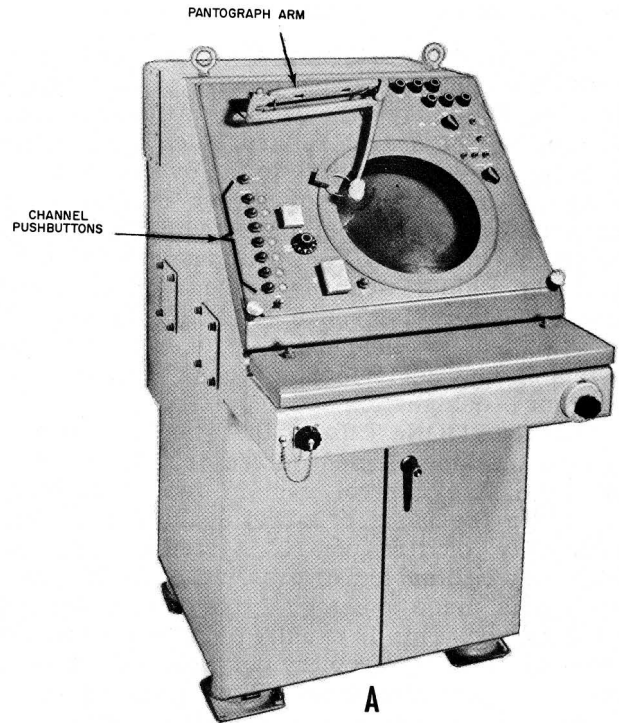

12,42
 Figure 6-2.— Typical weapons direction equipment: A, Target selection and tracking console; B, Plan Position Indicator (PPI) display on console.

CHAPTER 6 - A TYPICAL GUN AND MISSILE WEAPONS SYSTEM

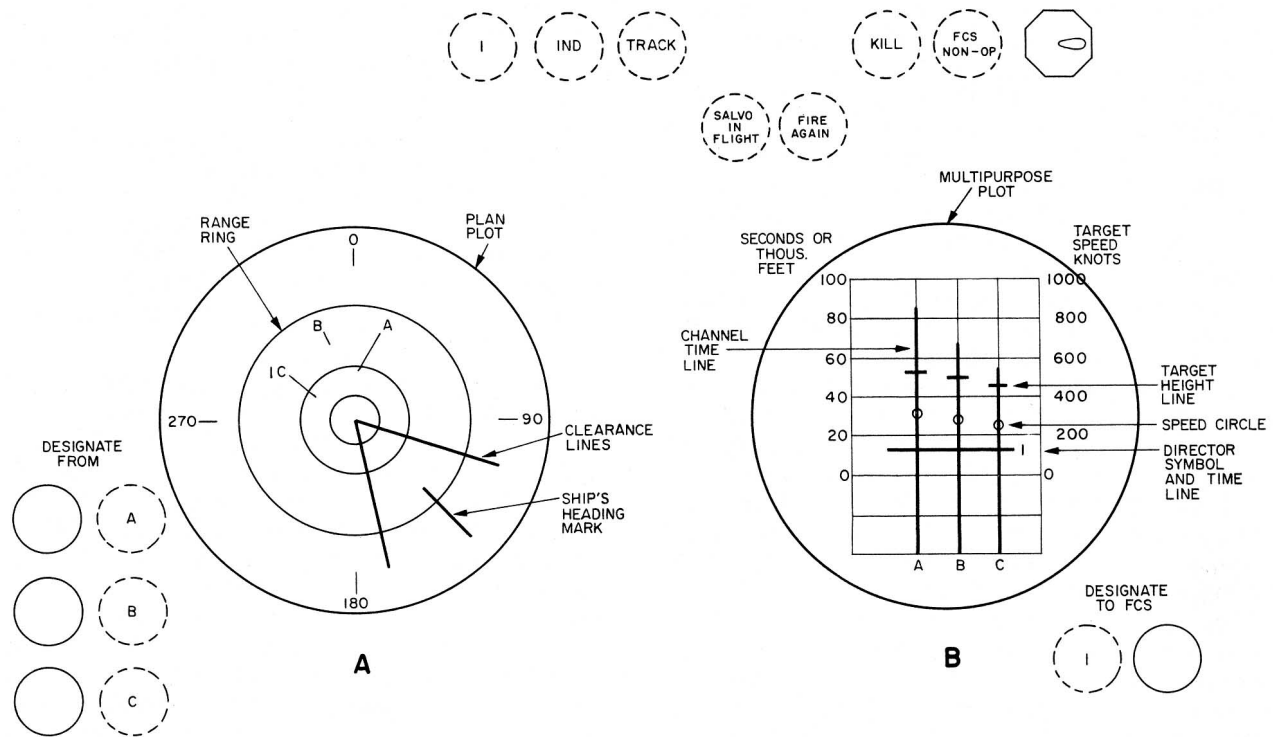

12.43

Figure 6-3.—Director assignment console display: A. Plan plot; B. Multipurpose plot.

the display as a letter, corresponding to the tracking channel from which it originates. The figure shows that tracking channels A, B, and C are tracking three separate search radar targets. The straight line associated with target A indicates the course and speed of this target. The number 1 indicates the position of the radar set in the basic fire control system. If the weapons control system had more than one fire control system, these additional systems would have associated numerals. A ship's heading marker, and radial clearance lines on either side of it, are presented electronically and rotate when the ship changes course. The sector between the two clearance lines indicates the region into which we may not launch missiles because of danger of striking the ship's superstructure.

The multipurpose plot (fig. 6-3B) is used primarily for making time comparisons. These comparisons help the operator to decide which of several targets to designate to a director, and to plan the future handling of targets that cannot be assigned immediately. Once the radar set acquires the target and begins to track it, the fire control

system is busy solving the missile fire control problem. During this time the operator, with the aid of the information displayed on the plot, can decide which target is next in line for assignment to a tracking radar set.

The multipurpose plot is also used to indicate the speed and height of targets that are being tracked by the tracking channels. As you can see in figure 6-3B, it is divided into three vertical lines - each line representing a tracking channel. All changes in indications take place vertically, and you can read the values indicated as you would read a thermometer.

The vertical lines show, for each target, the time within which the radar set must be assigned and a missile fired in order to intercept the target before it can reach its Estimated Weapon Release Range (EWRR). The EWRR will vary, depending on the type of payload the enemy is carrying and on how accurately you guess what the payload is. This estimate range is manually inserted into the DAC and affects the length of the channel time line. The director symbol and time line (fig. 6-3B) comes into play only after the director is

assigned. As this line decreases to zero level, it indicates the time left in which you have to make a target intercept at the maximum effective range of your system before he (the target) reaches the release range of his weapon. (For example, if you guess that the target's payload is an air-to-surface beam-rider missile, the EWRR might be on the order of 25,000 yards. At the left of the plot you can read how much time you have to assign the radar set so that it can acquire the target, track it, solve the problem, and load and fire a missile salvo, and have the missiles intercept the target before the target can release its missiles. This points up the need for quick evaluation. In conjunction with the plan plot, the multipurpose plot provides the necessary information to speed up this process. It relieves the human operator of the necessity of remembering how much average time each component in the weapon system requires to perform its function under varying conditions.

The scale used to measure assignment time is also used with the height line. The height line is a short horizontal bar which moves up and down the vertical channel line as target altitude changes (fig. 6-3B). In this case the number represents thousands of feet. To the right of the display is a target speed scale (marked knots) which is used in conjunction with the speed circle. The speed circle rides up and down to indicate target speed.

The long horizontal line shown in this plot represents busy time for the radar set. When the radar set is not acquiring or tracking, the time line and director symbol number rest at zero time. But when the radar set is assigned a target, the time line and symbol move up to indicate the time during which the set will be busy with that target; they slowly move down as time elapses. After a missile salvo is launched, the line and symbol continue to move downward until they reach zero. The missile should then have intercepted the target, and the radar set is ready to be assigned a new target.

Above the two display plots is a field of lamps relating to the gun and missile fire control system. The lamp with the numeral 1 in it is called the BUSY lamp. (If our basic weapon control system had more than one fire control system, each of them would be represented by a different lamp and number.) The BUSY lamp is sighted whenever the radar set is assigned a target. The IND lamp is lighted when the radar set is operating independently of the weapon direction equipment, as in tracking drill

or radar calibration exercises. The TRACK lamp indicates that the assigned target is gated and is being tracked. The KILL lamp lights when a target has been destroyed. The observation of the kill is usually visual.

The FCS NON-OP lamp indicates that some part of the fire control system is not in operation. When missiles are launched, the SALVO-IN-FLIGHT lamp lights. If another salvo is ordered to be fired, the FIRE-AGAIN lamp lights to indicate that this order has been sent to the weapon assignment console, but that the salvo has not yet been fired.

The pushbuttons at the lower left labeled DESIGNATE FROM, and the pushbutton at the lower right labeled DESIGNATE TO FCS, are used in making assignments of the radar set to one of the three tracking channels, A, B, or C. The operator makes the assignments by simultaneously pressing the selected 'designate from' button and the "designate to FCS" button until both lights function. This process connects the radar set to the selected tracking channel and slews the radar set automatically onto the target. At this time the radar repeat-back symbol moves until it is superimposed on the track channel symbol. This indicates to the director assignment console operator that the radar is tracking the proper target.

WEAPONS ASSIGNMENT CONSOLE

The Weapons Assignment Console (WAC), is designed to operate with the fire control system and launcher. It displays data from the fire control system, giving the target's present and predicted intercept positions, and information from the computer indicating whether or not missile intercept is possible. It also has a summary display of launcher information.

The missile firing key is located on the weapon assignment console. Decision of whether or not to fire is made from this station. The target may be out of range, for example, and this information would be shown on the console.

The console has a cathode-ray tube display showing a horizontal plot and true bearing, with own ship's position in the center. Around this plot is a fixed bearing ring. Radial lines from the center to the edge of the plot, generated electronically, indicate launcher unclear areas caused by ship's heading. These lines rotate with changes in ship's heading. This display is similar to the plan plot of the director assignment console (fig. 6-3A).

CHAPTER 6 - A TYPICAL GUN AND MISSILE WEAPONS SYSTEM

The other indications on the cathode-ray tube display appear only while the fire control system is tracking a target. These indications are:

1. An "X" indicating target present position.
2. A small circle indicating target future position at the predicted point of intercept.
3. A large circle about the center, which indicates the maximum range the missile can reach at the target's predicted altitude at intercept.
4. A thermometer type display at the left hand edge of the plot, giving the target's predicted altitude at intercept (H).

LOCATION AND OPERATION OF CONSOLES

Directors, gun mounts, and missile launchers are mounted on the deck; search radars are above the deck. Normally, missile directors are not manned and have no optical tracking equipment. Full radar control is the only type of operation possible. There are no provisions for local operation in the director although the radar operator can position the director from the radar console. In both gun and missile directors, the optics and radar antenna are stabilized to a varying degree. Target data are transmitted to the computer.

Optics are used chiefly for gunfire control. Gunsights, gunsight telescopes, lead-computing sights, and optical rangefinders are examples.

Figure 5-8 shows the shipboard location of missile system components on three types of ships, CAG, CLG, and DLG. The search radars, high up on the ship's superstructure, scan the surrounding sea and sky for targets for all types of weapons. They transmit target data to the weapon direction equipment where the signals appear on the scopes, to be interpreted by the operators. The computer converts the radar signals for presentation on the PPI-scope (fig. 6-2).

In case of casualty to the primary search radar, a secondary source of target information may be available from other search radars. (Not all ships have a secondary source.)

If there are multiple targets, which is likely to be the case in an attack, the threat of each target must be evaluated. With today's supersonic planes, missiles, and swift ships and submarines, the time to make decisions is very limited, and a weapon director must be assigned very quickly to the most threatening target. The technicians

and officers in CIC study the target's indications and movements even before the target video signals show on the weapon direction equipment. A target tracking radar is quickly assigned to pinpoint the location of the target, determine its speed, and height (for air targets). This information enables the weapons officer to determine which weapon is best suited to engage the target, and a director is assigned, either a gun director or a missile director. The positions of the targets in the tracking channels are transmitted continuously to the director assignment console. The console operator evaluates the targets on the basis of this information and assigns a fire control system. The weapon assignment console has charge of launcher assignment and selection of the missile. This time of missile firing is very important since we must strike for missile intercept before the target reaches its release point, and releases its own missile. This means that loading time must be precisely controlled. Each GMM must do his job with speed and precision.

Missiles must have a certain warmup period before being fired; but it must not be too long, or the electronic balance will be upset by the heat generated within the missile. This means that the missile cannot be energized well in advance of the expected launch. The WAC operator must make a decision as to when to begin warmup.

A TYPICAL FIRE CONTROL SYSTEM

Gunfire control systems are adequately covered in the preceding chapters. In chapter 2 we discussed basic gun fire control principles and the elements of gun fire control systems; therefore these systems and equipments will not be discussed in detail here. In this section we will discuss only the equipments that make up the fire control system of a typical guided missile ship.

Look again at figure 6-1. We have assumed that the fire control system shown in the illustration is capable of controlling gun and missile batteries at the same time. This is a valid assumption because there are systems of this type in the fleet - Tartar, for example.

The fundamental fire control problem contains three basic elements - a line of sight, a prediction angle, and a line of fire. The line of sight is established optically or by radar, using a director or a radar set. A fire control computer produces the prediction angle in the form of gun and missile

orders. These orders are transmitted to the guns and missile launchers to position these equipments along their respective lines of fire. The above statements indicate that there are two basic equipments needed to solve the fire control problem when guns and missiles are used as weapons. These two equipments are a director and a computer. You might add another instrument - the stable elements, but its function is sometimes performed by a device included in the director. So we can say that a complete fire control system contains a director, a computer, and a stable element which may or may not be a separate unit. When separate, the computer and the stable element (fig. 6-4) always operate as a pair. Directors, gun mounts, and missile launchers, mounted on the deck, measure their position with respect to the deck plane. Ship's roll and pitch are independent of target position, and therefore affect all measurement of target's position and motion. Stabilization is needed to keep the line of sight on target and the line of fire on an aiming point in space. Corrections are needed by the computer for LOS and LOF.

FUNCTIONS AND PROBLEMS OF FIRE CONTROL

Any combined gun and missile fire control system has four primary basic functions: to acquire and track targets; to develop launcher, gun, and missile orders; to guide missiles to the target; and, in some instances, to detonate the missile warhead.

Secondary functions of the system are to provide target information such as target speed, target course, range to the target, and system and weapon status information to the display units of the weapon direction system. This information is used to evaluate the tactical situation and to aid in the fire control system and weapon assignment

The Director or Radar Set

The director or radar set is the eyes of the fire control system. It can search for, detect, acquire, and track a target; and it can "capture" and guide a missile. At this point let's stop and consider the terms "director" and "radar set." There may be some confusion in your mind as to their exact meaning. The equipments perform the same functions in the weapon system, but they have different physical arrangements. A director contains a radar and/or optics for tracking and ranging, and it is usually manned

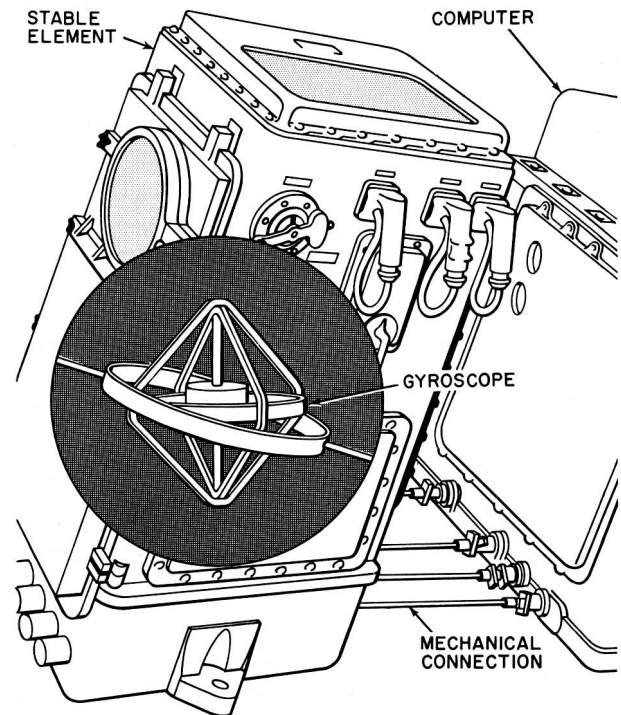

51.103

Figure 6-4. — The stable element is a gyroscopic device.

(in gun or gun/missile fire control). A radar set has no optical tracking device or rangefinder. It is not manned in the sense that a man is located inside the antenna supporting structure. True, there is an operator in the radar control room; but his primary function is to monitor the equipment and make sure it is functioning properly.

In the rest of this chapter we will use the term "radar set," rather than director, because that name has been given to the newer equipments that perform the same function as a director.

The radar set described here, and illustrated in figure 6-1, is an automatic-tracking gunfire control and missile guidance radar. It receives target designation data from the weapon direction equipment, and uses this information to acquire and track a designated target. If guns alone are used to fire on the target, the radar set tracks the target to provide information needed to solve the gunfire control problem. If guided missiles are used, the radar not only tracks the target

but transmits radar signals to capture the missile and guide it to the target (if it is a beam-rider or a command guidance missile).

Of course, as we have mentioned before, the radar set performs all these functions simultaneously if guns and missiles are used at the same time. Also, it can operate as a search radar if circumstances require.

The radar set can transmit simultaneously, on a common nutation axis (fig. 4-3), three distinct beams of radar energy—the tracking, capture, and guidance beams. A narrow tracking beam first acquires and tracks the target automatically. The wide angle capture beam captures the missile after launch, and holds it until it enters the narrow guidance beam (fig. 4-19) that guides it to the target. The capture and guidance beams are transmitted simultaneously; the missile distinguishes between the two because they are coded differently.

The radar set consists of two major groups of equipment: an antenna group, and a control and power group. The antenna group, which is located above deck, consists of a pedestal upon which are mounted the antenna and the necessary electrical and mechanical components required to stabilize and position the antenna. Housed inside the mechanical structure of the antenna group are the transmitting, receiving, and associated microwave circuits. Here, too, are located the gyroscopes that space-stabilize the antenna, and thus the radar beams, to compensate for the roll and pitch of the ship.

The control and power equipment group is located belowdecks in a compartment usually called the radar room. This room contains the radar consoles used to operate, monitor, and control the radar set. Also located in the radar room are the cabinets containing the power supplies that provide the operating voltages for the various units in the radar set.

Typical Gun and Missile Computer

The typical gun and guided missile fire control computer described here is an electromechanical type designed to operate automatically. No operating personnel are needed. It is located in the ship's plotting room, and is used with the radar set described previously. The computer is a dual ballistic computer. In other words, it solves the gun and missile fire control problems simultaneously.

The computer has three basic ways of operating. It can operate when designation is desired; then, after the radar set has acquired

the designated target, the computer aids the radar set in tracking it. As soon as the guns and/or missiles have destroyed the target, the computer shifts to the air-ready method of operation. These different methods of operating are called modes. The various modes of computer operation can be briefly described as follows:

AIR-READY MODE.—In this mode the computer is energized, but is receiving no information. It generates orders only to put the radar set, launcher, and guns in predetermined air-ready positions. For example, the air-ready position of the radar set may be at zero° of train and 45° of elevation; the launcher air-ready position may be at 180° of train and zero° of elevation.

DESIGNATION MODE. - The computer goes into this mode of operation when it receives a "director assigned" signal from the director assignment console of the WDE. The computer directs the radar set to the designated target position so that the radar line of sight will point at the target. It also sends a search program to the radar set. The search program causes the radar beams to move in a preset pattern about the designated target position. The radar searches for the target, and when the target is gated the computer automatically goes into the track mode of operation.

TRACK MODE. - When the radar set acquires the target in range, bearing, and elevation, the track mode starts. The radar set then transmits an on-target signal to the computer. The computer sends signals to the radar set that cause it to drive at a rate that will keep it locked on the target. The computer determines the proper lead angles for the launcher and guns, and transmits these quantities to them in the form of electrical signals. These signals drive the guns and launcher to the proper aiming positions.

Before the missiles are launched, the computer determines and transmits to the missiles quantities that move the missile gyros to their proper positions. The computer also transmits, to the various display consoles of the WDE, tactical data such as present target position, future target position, and missile time to target intercept (time of flight).

DELIVERY UNITS IN A TYPICAL WEAPONS SYSTEM

The delivery units of a typical weapons system are the gun mounts and the missile launcher. This section sums up operation of a typical

GUNNER'S MATE M 3 & 2

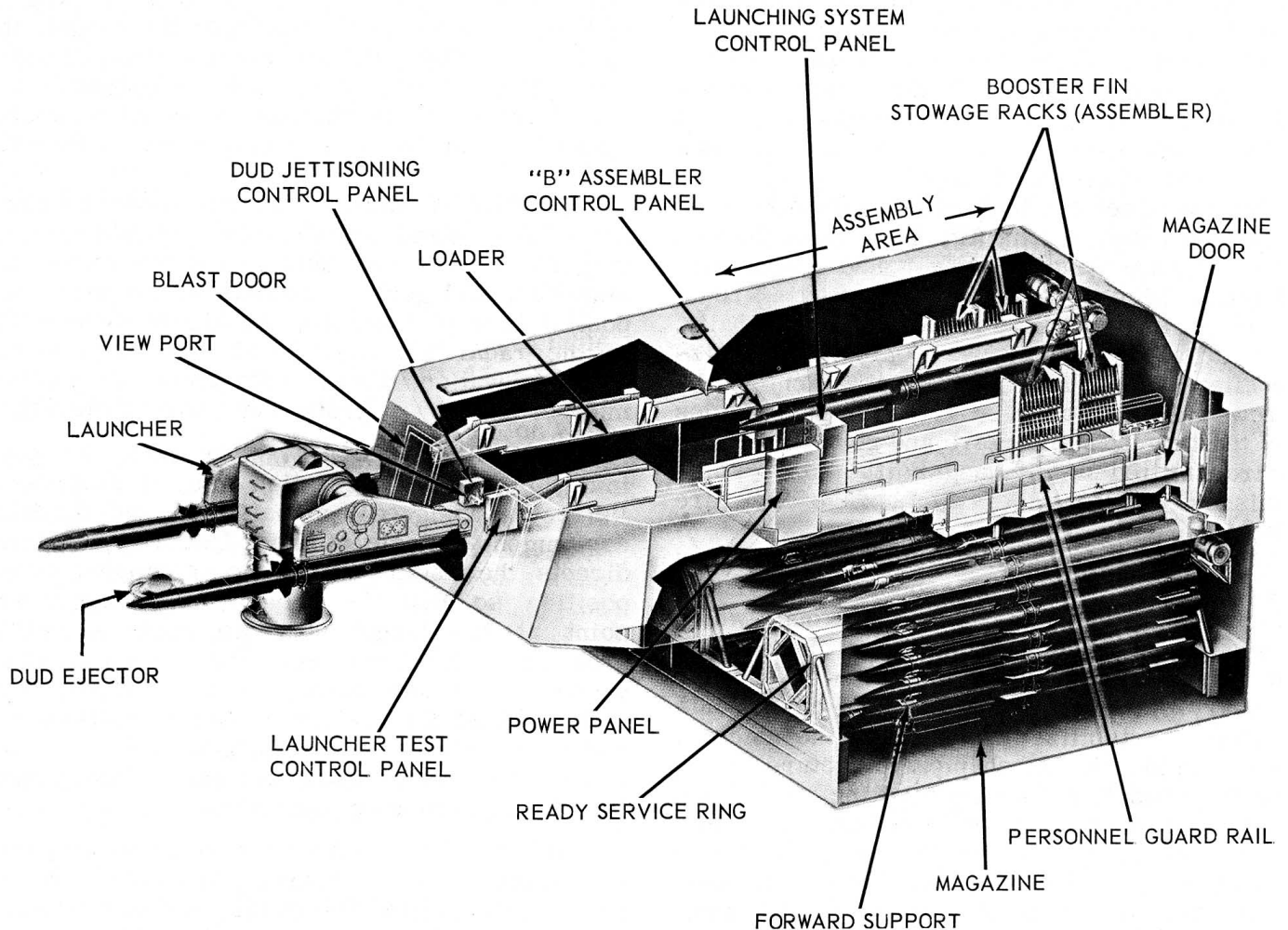

12.44

Figure 6-5. — Typical Terrier missile launching system Mk 10 Mods 0 to 6.

missile launcher and the equipments associated with it. Guns are covered in Military Requirements for PO 3&2, NavPers 10056-B, and Seaman, NavPers 10120-E.

Guided Missile Launching System

The guided missile launcher shown in figure 6-5 is part of a group of equipments that are known collectively as a Guided Missile Launching System. A guided missile launching system has three major components:

1. Guided missile launcher
2. Guided missile launcher feeder
3. Guided missile launching system control

The primary purpose of a guided missile launching system is to stow missiles until needed and then supply them to a launcher for firing. Its secondary function is to remove unfired missiles from the launcher and return them to the missile stowage area (or jettisoning them in case of dangerous misfire or a dud). In missile replenishment, too, the launching system equipment is used to strike the missiles below to the magazine, or to bring them up for unloading.

GUIDED MISSILE LAUNCHER. - All Navy missiles that are launched from ships (not including submarines) use short rail launchers. (These launchers are commonly called Zero Length launchers.) This type has one or two, usually two, launcher arms (or rails). The launcher shown in figure 6-5 is the dual-rail type. It receives

CHAPTER 6 - A TYPICAL GUN AND MISSILE WEAPONS SYSTEM

and secures two complete missiles - one on each launcher arm... The launcher automatically trains and elevates in response to synchro signals (missile launcher orders) from the fire control computer. Through electrical connections on the launcher arms, the missiles (except Standard) receive warmup power before launch. Warmup power is used to bring the missile gyros up to speed, and to warm up the vacuum tubes, without taking power from the missile power supplies. Preflight information is also supplied to the weapon through contactors in the launcher arms, and the firing circuit is connected through the launcher to the missile's internal firing circuitry. The launcher can automatically return to a predetermined fixed position in which a new missile can be loaded on the launcher arm, or an unfired missile can be returned to stowage.

GUIDED MISSILE LAUNCHER FEEDER. - The purpose of this group of equipments is to stow guided missiles and their boosters in magazines, to remove them from the magazines, and to load them on the launcher arms. There are several types of feeders, but they all have these two purposes. The feeder described here is the most common type. The other systems are similar in operating principles.

The feeder consists of three functional groups of equipment - the magazine, the loader, and the assembler. Figure 6-5 shows the magazine area. The main piece of equipment in the area is the ready-service ring, in which the missile-booster combinations are stowed. The ring can rotate like the magazine of an automatic revolver. This rotating motion of the ring is called "indexing." The ring is indexed to position a missile round so that it can be placed under the loader. The loader provides a means for removing the missile rounds from the ring and loading them onto the launcher rails. Figure 6-5 shows one loader rail. Usually there are two of them. Continuous grooves in the rails function as tracks to support the booster shoes during loading operations. The booster shoes are T-shaped and horseshoe-shaped lugs. The rails of the launcher arms are also grooved to receive these lugs. During the loading or unloading operation, the launcher is positioned so that the loader rail and launcher rail form one continuous track. Missiles are loaded onto or unloaded from the launcher by a loader chain that is guided by a track in the loader rail. A hook, or pawl, attached to the chain, engages the rear shoe of the booster.

The third group of equipments that make up the feeder is called the assembler. The assembler is essentially a set of racks for stowage of the aerodynamic surfaces (booster fins and missile wings). The wings and fins are mounted on the booster and missile manually, by men assigned to perform this operation.

GUIDED MISSILE LAUNCHING SYSTEM CONTROL. - This equipment group includes the panels used to operate the missile launching system. The power panels contain circuit breakers, overload relays, and other electrical components required by the various power drives that control the movement of the launcher, rammer, and ready-service ring. Other panels contain operating controls that are used to start the system and control its operation. These panels normally respond to orders from the WDE. For example, the WDE may send an order to ALERT the missile launching system. An ALERT light on a panel flashes, indicating to the operator that WDE wants the missile launching system's equipment put into operation. The orders transmitted from the WDE to the missile launching system are of interest to the GMM, for he must learn to operate the control panel at any station in the launching system.

Types Of Orders. - The MISSILE SELECT order is transmitted from the WDE to the launching system to indicate the type of missile to be loaded on the launcher. There are several types of Terrier missiles. All of these types may be loaded together in a single magazine. This is called mixed loading. When the launching system has selected the type of missiles called for by the WDE, it sends back a signal indicating that the order has been carried out.

The LOAD order tells the launching system to start loading a missile or missiles. A load order may be "continuous," "single," or "hold." A "continuous" order causes missiles to be continuously supplied to the launcher. This operation is similar to "rapid or continuous fire" in conventional gunnery. The "single" order causes one missile per arm to be loaded on the launcher. The "hold" order holds the launching system in a ready-to-load condition.

When the launching system receives the UNLOAD order, it unloads any missiles that may be left on the launcher arms, returning the missiles to the magazine. In some mods, this can be done in automatic operation; in others it must be done in step operation.

The INTENT-TO-LAUNCH (ITL) is similar to the conventional "commence fire" order in

one respect- it is transmitted by closing a firing key. But, while the gun firing circuit is completed almost instantly when the key is closed, there is a slight delay before a missile firing circuit is completed. This delay is necessary to establish certain operating conditions in the missile, and in other equipments in the weapons system. Before the missile can be fired, it must indicate that it is ready to be launched. This indication, "missile-ready-to-fire," is sent through the launching system control circuits back to the WDE. Almost every piece of equipment in the weapons system affects the operation of the firing circuit, either directly or indirectly.

Gun Battery

There are a number of situations in which a missile is not the best weapon. The target may be too close, or it may be too small to be worth expending a costly missile to destroy it. The search radars locate the targets, and the tracking radars (or directors) track the target and pinpoint its location. From the information shown on the display scopes in CIC, the weapons officer must decide what weapon to use against each target and must transmit his orders so action will be taken at once. Multiple targets may require the use of several kinds of weapons simultaneously. Radars can search and track more than one target at a time, and certain computers are capable of solving gun and missile fire control problems simultaneously.

DESTRUCTION UNITS IN A TYPICAL WEAPONS SYSTEM

As we mentioned earlier in this chapter, our typical weapons system is designed to control two weapons, the gun (projectile) and a homing or a beam-rider missile. These weapons have been discussed in this book, or in the books in the reading list. In addition to surface-launched weapons, there are air-launched and underwater-launched weapons. These are not discussed in this book, but you have been given basic descriptions in Seaman, NavPers 10120-E, and Military Requirements for PO 3&2, NavPers 10056-B.

WEAPONS SYSTEM FUNCTIONING

To provide a brief review of what you have studied so far in this chapter, we will list the principal steps or phases a typical weapons

system goes through to accomplish its mission. The mission, of course, is to destroy the enemy or a practice target. The principal steps, in chronological order, are:

1. TARGET DETECTION. Search radars detect targets at long ranges, to allow time for the weapons system to go into action and complete its function.

2. TARGET SELECTION- From the information supplied by the search radars, the weapons direction system selects the targets that appear hostile, and that require missile and/or projectile interception, and inserts them into tracking channels. Target selection and tracking is performed by personnel assigned to the target selection and tracking console-a unit of the weapons direction equipment.

3. SEARCH RADAR TARGET TRACKING. The tracking channels (computing circuits) continuously track selected search radar targets to generate target rate of movement. This data appears as a symbol (letter) on the face of a large cathode-ray tube (scope). When the tracking channel has computed the correct target course, speed, and rate, the symbol on the scope will remain superimposed on the target echo supplied by the search radar. This computed target position and rate data are used for evaluation of the tactical situation presented to the ship, and for transmission to other units in the WDS - especially the director assignment console. Each target that is being tracked is assigned a different symbol to prevent confusion.

4. EVALUATION. The weapon system evaluates the threat of various targets, decides which should be engaged by guns and which by missiles, and decides which targets should be given the priority. The evaluation is performed by personnel, but they are aided in this process by the displayed information on the various consoles in the WDE and CIC.

5. DIRECTOR ASSIGNMENT. A radar set is assigned to the target having the highest priority. When a radar set is assigned, this implies that a fire control system has been included in the assignment.

6. ACQUISITION., The assigned radar set (fire control system) gets on the target.

7. TRACKING. The fire control radar tracks the target to provide precise target position and rate data. The computer associated with the tracking radar operates on the data from the radar set to provide the solution to the fire control problem. The computer answers are

CHAPTER 6 - A TYPICAL GUN AND MISSILE WEAPONS SYSTEM

supplied to the guns and launcher as synchro signals to position these units in train and elevation.

8. REEVALUATION AND WEAPON ASSIGNMENT. The target that is engaged by the fire control system is reevaluated with respect to the tactical situation (this may have changed), availability of the launcher or gun, and the range limitations of the weapons.

9. LOADING. Missiles are loaded on the launcher, and the guns are prepared for firing.

10. LAUNCHER SYNCHRONIZATION OF MISSILE ORDER INPUTS. Synchro transmitters and receivers are inherently "self-positioning" or synchronizing. A synchro system is used to transmit a training order from the director to the launcher. The synchro transmitter, mounted on the director and geared to it, transmits the movement and position of the director. The dial of the synchro receiver in the launching equipment constantly indicates the director's position. The launcher will train to match the receiver dial. The synchros are connected electrically, but the launcher is moved in train and elevation by hydraulic power. The synchros actuate hydraulic pilot valves that actuate and control the hydraulic system.

The launcher is capable of unlimited train (unless located in a position where this is not possible). The guide rails may be elevated between -10° and $+90^{\circ}$ with respect to the deck (for Tartar systems) though the maximum angle of fire is 85° . "Stow" and "load" positions for Terrier Mk 10 systems both are between 1° and 3° (varies with Mod) elevation and 180° train, but Tartar systems load and stow at 90° elevation, Latches secure the launcher in the required load or stow position.

An ever-present problem is the limitation placed upon firing arcs by the ship's superstructure. The launchers guns are electrically cut out if they are aimed at any part of the ship. The mechanical actuator is the nonpointing zone cam, The cutout area is referred to as the blind zone for the weapon. An aft gun or launcher cannot fire dead ahead at low elevation angles, and a forward gun or launcher is cut out directly aft, except where the gun or the launcher guide can be elevated above the firing cutout zone.

Synchronizing networks or circuits may use relays, diodes (semiconductor and vacuum tubes), and gas tubes (thyatron or neon). The purpose of the synchronizing circuit is to prevent overspeeding of the drive where large changes are necessary. If a large error signal is allowed

to drive the equipment at an excessive speed, and there is a radical change of target speed or direction, the inertia of the moving heavy equipment could be so great as to drive past synchronism. The time required for the launcher to synchronize is about 5 seconds. Upon assignment, the loaded launcher synchronizes in train and elevation with the launcher orders generated by the computer. The Launcher Status Console operator supervises missile and launcher readiness, noting that the launcher is synchronized and that missiles are warmed up and ready to fire. The sequence of operations is similar for all surface launched missiles. After the missile is on the guide arm and the blast doors are closed, the launcher train and elevation latches retract. The launcher starts to synchronize to the director and synchronizes to the firing position. The salvo firing circuit is closed and the missile is activated. The arming tool winds and retracts, the guide arm contactor retracts and the booster is ignited.

The missile clears the guide arm rails. Then the missile on the other guide arm is fired. If the order is for continuous firing, other missiles are brought up from the magazine, the wings and fins attached, and warmup applied. As soon as both guide rails are empty, the launcher synchronizes to load position, and the cycle is repeated.

11. LAUNCHING AND FIRING. The missiles are launched at the proper time and in the proper direction. The guns are loaded and fired.

12. MISSILE GUIDANCE. The fire control radar guides each missile to the target being tracked. Gun projectiles, of course, receive no guidance.

13. TERMINAL PHASE. When a missile or projectile approaches to within lethal range of the target, a VT fuze detonates its destructive charges. This is the "moment of truth" for the weapons system.

INTERSYSTEM COMMUNICATIONS

All the information gleaned by radars and computed by computers is of no value if it is not available to decision-making personnel. The information must be available instantly to officers, petty officers, and other men who have the knowledge and competence to interpret and apply it. A complicated network of communications, with duplicate equipment to take over in case of failure or damage, is necessary to keep data transmission a continuing process. Figure 6-6 is a simplified schematic of the flow of data in

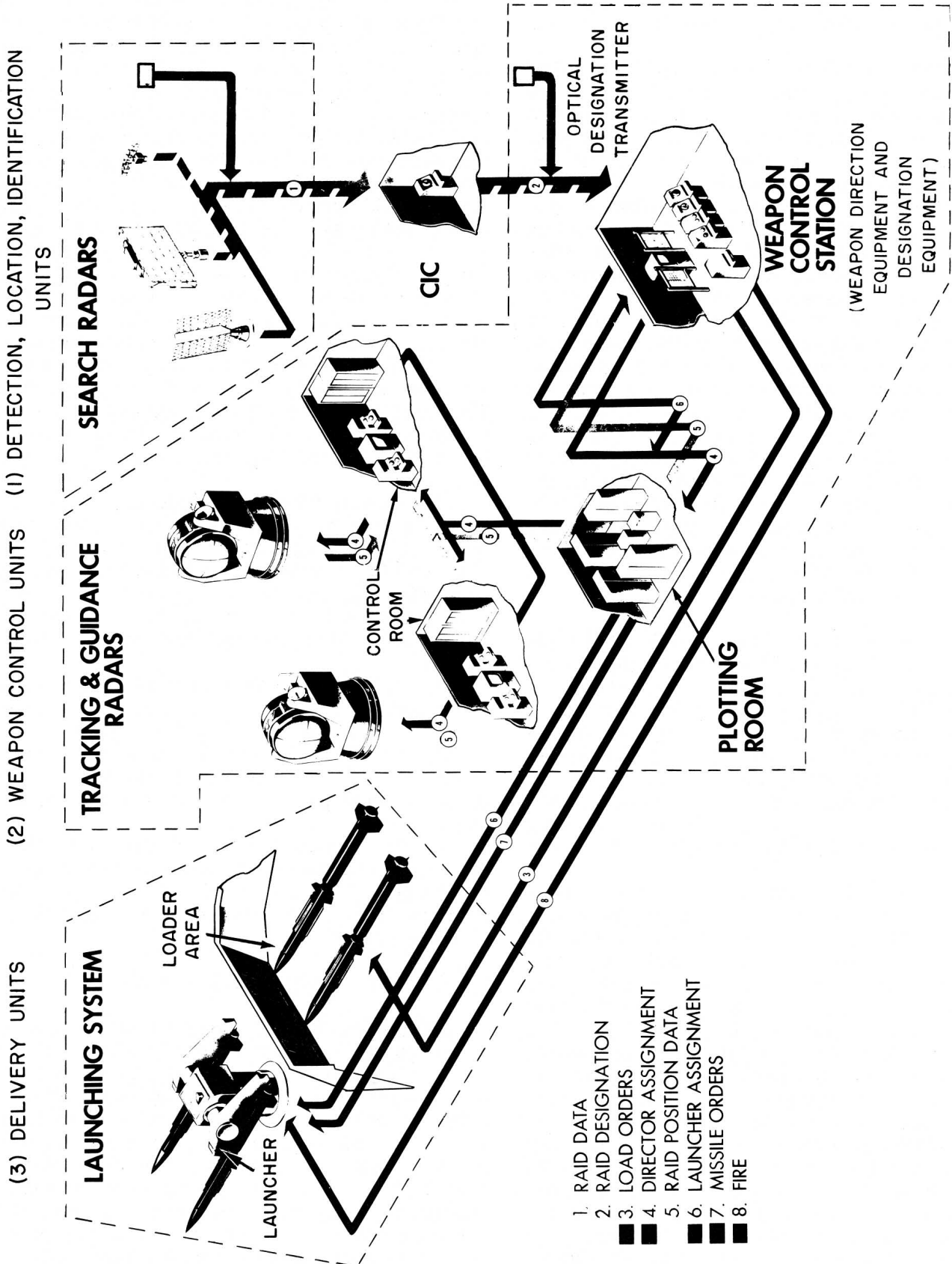

94.8

Figure 6-6. — Flow of data and orders in Terrier weapon system; simplified schematic.

CHAPTER 6 - A TYPICAL GUN AND MISSILE WEAPONS SYSTEM

a Terrier weapon system. Let's follow through on the flow of data in a typical weapon system.

The search radars in figure 6-6 include a surface search radar (AN/SPS-10), a primary search radar with pencil-beam for long-range scanning (AN/SPS-26), and a fan-beam radar for long-range aircraft detection (AN/SPS-29). Targets not identified by the radars are challenged by IFF. Results are relayed to CIC, the Pilot House, and the Weapons Control Station, where they are displayed on scopes. IFF is normally controlled from CIC. By switching at the radar distribution switchboard, the radars can be connected directly to the target tracking consoles. The optical designation transmitter is used if there is failure of the search radars or if the target is too low for detection by search radars.

The designation equipment has a target selection and tracking console in WCS and another in CIC. From the information displayed on the PPI-scope, CIC assigns tracking channels for the targets in the order of their apparent threat. Telephone communications are available for all

personnel in the system. so decisions and changes can be given verbally to supplement (or replace) pushbutton signals.

The operator of the Director Assignment Console (in WCS), on the basis of information from the tracking radars and director displayed on his console, assigns a missile launcher or a gun system to a particular target.

The operator of the Weapons Assignment Console (in WCS), studying the display of information on his scope, selects the missile rail to be loaded, the method of loading (single or continuous), pushes the button that initiates warmup power to the missile, selects the number of missiles to be fired per salvo, and assigns the launcher to a fire control system. He can also cancel the launcher assignment.

At the control panel in the launcher system, the operator watches the succession of lights and, if anything is wrong, he immediately notifies CIC. It may be necessary to select another missile or even assign another launcher; the target does not wait for repairs to be made.

The whole operation takes less time than it takes to tell about it. Each man must be master of his job.